



Control Unit

NRS 1-40.1

NRS 1-40.2



CANopen

EN
English

Original Installation Instructions
818548-02

Contents

Page

Important Notes

Usage for the intended purpose	4
Safety note	4
Danger	4
Classification pursuant to article 1 of the Pressure Equipment Directive (PED)	4
ATEX (Atmosphère Explosible).....	4
Note on the Declaration of Conformity / Declaration by the Manufacturer CE	4

Explanatory Notes

Scope of supply	5
System description	5 – 7
Function	8

Technical Data

NRS 1-40.1 / NRS 1-40.2	9, 10
Name plate / Marking	10
Dimensions NRS 1-40.1 / NRS 1-40.2	11

Installation

Control unit NRS 1-40.1 / NRS 1-40.2.....	12
Change settings.....	12
Mount control unit	12
Tools	12

Functional Elements

NRS 1-40.1 / NRS 1-40.2	13
Key	13

Electrical Connection

Bus cable, cable length and size	14
Change baud rate	14
Wire terminal strip	14
Note	14
CAN Bus voltage supply	15
Wiring diagram for control unit NRS 1-40.1	16
Wiring diagram for control unit NRS 1-40.2	17
Wiring diagram for CAN bus system – example –	18
Attention.....	18
Note	19
Tools	19

Basic Settings

Factory settings	20
------------------------	----

Contents – continued –

Page

Commissioning

Danger	20
Change configuration	20, 21
Note	21

Start, Operation, Alarm and Test

NRS 1-40.1 / NRS 1-40.2	22
Note	22

System Malfunctions

Causes	23
Note	23
Danger	23
Systematic fault finding procedure for system malfunctions	24, 25
Fault finding list for troubleshooting system malfunctions: Limiters 1–4	26
Fault finding list for troubleshooting system malfunctions: Control unit	27
Action against high frequency interference	27
Replace control unit	28

Check Installation and Performance

Check switchpoints	28
--------------------------	----

Malfunctions

Fault finding list for level electrode NRG 1.-40 / control unit NRS 1-40.1	29
Fault finding list for level electrode NRG 1.-41.1 / control unit NRS 1-40.1	30
Fault finding list for level electrode NRG 1.-41 / control unit NRS 1-40.2	30
Fault finding list for temperature transmitter TRV 5-40 / control unit NRS 1-40.1 / NRS 1-40.2	30

Emergency Operation

Emergency operation of water level limiting system LW	31
Attention	31

Annex

CAN bus	32
Setting the node ID	32, 33
Note	33
Danger	33
Attention	33
Decommissioning	34
Disposal	34

Important Notes

Usage for the intended purpose

The control units NRS 1-40.1 / NRS 1-40.2 must only be used in conjunction with the associated sensors for monitoring water level and temperature limits.

The equipment can be used as

- low-level limiter (min. water-level alarm) or as low-level limiting system in conjunction with level electrode NRG 1x-40, (only NRS 1-40.1),
- high level alarm in conjunction with level electrode NRG 1x-41 or NRG 1x-41.1 and
- safety temperature controller/limiter in conjunction with temperature transmitter type TRV 5-40.

A combination of these functions is possible.

Safety note

The equipment must only be installed and commissioned by qualified and competent staff. Retrofitting and maintenance work must only be performed by qualified staff who – through adequate training – have achieved a recognised level of competence.



Danger

The terminal strips of the control units NRS 1-40.1 / NRS 1-40.2 are live during operation. This presents the risk of severe cases of electric shock!
Always **cut off power supply** to the equipment before mounting, removing or connecting the terminal strips!

Classification pursuant to article 1 of the Pressure Equipment Directive (PED)

Category	IV
Designation	Safety accessory
CE marking	CE 0525

ATEX (Atmosphère Explosible)

According to the European Directive 2014/34/EU the equipment must **not** be used in potentially explosive areas.

Note on the Declaration of Conformity / Declaration by the Manufacturer CC

For details on the conformity assessment according to the European Directives see our Declaration of Conformity or our Declaration of Manufacturer.

The current Declaration of Conformity / Declaration of Manufacturer are available in the Internet under www.gestra.de/document or can be requested from us.

Explanatory Notes

Scope of supply

NRS 1-40.1 / NRS 1-40.2

- 1 Control unit NRS 1-40.1 / NRS 1-40.2
- 1 Terminating resistor 120 Ω
- 1 Installation manual

System description

The control units NRS 1-40.1 / NRS 1-40.2 have four limiting functions for monitoring the MIN/MAX water levels (low/high level alarms) and MAX temperature in steam and (pressurised) hot water plants in accordance with TRD and EN 12952 and EN 12953.

The level electrodes type NRG 1x-40, NRG 1x-41.1 and the temperature transmitter type TRV 5-40 detect the current water level and temperature and their readings are sent as a data telegram to the CAN bus.

The CANopen protocol is used for the data transfer via CAN bus.

Only one limiting system with one control unit NRS 1-40.1 or 1-40.2 may be used per CAN bus network.

The application of the control unit NRS 1-40.1 or NRS 1-40.2 makes it possible to switch off different electric circuits, e. g. the safety circuit for the heating system and the control circuit for the feed pumps or circulation pumps.

Explanatory Notes – continued –

System description – continued –

By connecting the level electrodes and the temperature transmitter with the control unit the following combinations of functions are possible:

Control unit NRS 1-40.1			
Function 1	Function 2	Function 3	Function 4
Low-level limiter (LW alarm) Level electrode NRG 1x-40			
Low-level limiter (LW alarm) 1 Level electrode NRG 1x-40	Low-level limiter (LW alarm) 2 Level electrode NRG 1x-40		
Low-level limiter (LW alarm) 1 Level electrode NRG 1x-40	Low-level limiter (LW alarm) 2 Level electrode NRG 1x-40	Safety temperature monitor/limiter Temperature transmitter TRV 5-40	
Low-level limiter (LW alarm) 1 Level electrode NRG 1x-40	Low-level limiter (LW alarm) 2 Level electrode NRG 1x-40	High level limiter (HW alarm) Level electrode NRG 1x-41.1	Safety temperature monitor/limiter Temperature transmitter TRV 5-40
Low-level limiter (LW alarm) 1 Level electrode NRG 1x-40	Safety temperature monitor/limiter Temperature transmitter TRV 5-40	Safety temperature monitor/limiter Temperature transmitter TRV 5-40	
Low-level limiter (LW alarm) 1 Level electrode NRG 1x-40	Low-level limiter (LW alarm) 2 Level electrode NRG 1x-40	Safety temperature monitor/limiter Temperature transmitter TRV 5-40	Safety temperature monitor/limiter Temperature transmitter TRV 5-40
Safety temperature monitor/limiter Temperature transmitter TRV 5-40			
Safety temperature monitor/limiter Temperature transmitter TRV 5-40	Safety temperature monitor/limiter Temperature transmitter TRV 5-40		

Explanatory Notes – continued –

System description – continued –

Control unit NRS 1-40.2			
Function 1	Function 2	Function 3	Function 4
High-level limiter (HW alarm) Level electrode NRG 1x-41			
High-level limiter (HW alarm) Level electrode NRG 1x-41	Safety temperature monitor/limiter Temperature transmitter TRV 5-40		
High-level limiter (HW alarm) Level electrode NRG 1x-41	Safety temperature monitor/limiter Temperature transmitter TRV 5-40	Safety temperature monitor/limiter Temperature transmitter TRV 5-40	
Safety temperature monitor/limiter Temperature transmitter TRV 5-40			
Safety temperature monitor/limiter Temperature transmitter TRV 5-40	Safety temperature monitor/limiter Temperature transmitter TRV 5-40		

Function

At regular intervals the control unit NRS 1-40.1 / NRS 1-40.2 evaluates the data telegram coming from the level electrodes NRG 1x-40, NRG 1x-41, NRG 1x-41.1 and the temperature transmitter TRV 5-40. This data telegram contains:

- An alarm when the electrode NRG 1x-40 emerges and/or when the electrode insulation is defective,
- An alarm when the electrode NRG 1x-41.1 enters into the water and/or when the electrode insulation is defective,
- An alarm when the adjusted cut-off temperature is exceeded (temperature transmitter TRV 5-40),
- The result of the self-checking routine (detection of measured value),
- The temperature in the electrode terminal box and the casing of the temperature transmitter.

When a level or temperature alarm is raised the safety circuit is interrupted after the de-energizing delay. The control unit does not lock automatically. This function must be implemented in the following circuit.

The safety circuit will be interrupted instantaneously with the following malfunction alarms:

- Malfunction in the level electrodes (self-checking negative, temperature in terminal box too high),
- Malfunction in the temperature transmitter (self-checking negative, temperature in casing too high),
- Malfunction in the control unit (self-checking negative),
- Communication malfunction.

The self-testing routine checks the safety functions of the controller, the level electrodes and the temperature transmitter. This self-test is carried out every 3 seconds in the controller and every 10 seconds in all other pieces of equipment.

An additional self-testing routine checks every 6 hours the de-energizing of the output relays in the controller.

Malfunction messages are updated during each self-checking routine. If there is no malfunction the messages will be deleted automatically and the safety circuit is closed again. However, if the malfunction still persists, the malfunction message will remain.

Alarm and malfunction messages are indicated by LEDs, and the signal output is instantaneously energized.

Technical Data

NRS 1-40.1 / NRS 1-40.2

Type approval no.

TÜV. SWB/SHWS STW (STB). 03-413
EG BAF-MUC 03 07 103881 004

DIN registration no.

STW (STB) 117906

Input/output

Interface for CAN bus to ISO 11898 CANOpen

Output voltage supply for sensors

18 – 36 V DC, short-circuit protected

Output safety circuit

2 volt-free relay contacts, locally connected in series.

Contact material AgNi 0.15.

Max. contact rating with a switching voltage of 24 V AC/ DC, 115 V AC and 230 V AC:

resistive / inductive 4 A.

Provide contactors with RC combinations according to manufacturer's specification to ensure interference suppression.

Signal output

1 Photo MOS output for external signalling, alarm signal instantaneous, malfunction signal timed, 24-230 V AC/DC, max. current rating 100 mA, NO contact.

Factory setting of de-energizing delay of output relay

3 sec. (default setting)

other time delays (15, 25, etc.) on request

Indicators and adjustors

4 Pushbuttons for operation / "TEST",

4 LEDs for alarm and malfunctions messages,

1 LED "Power",

1 LED bus status, controller malfunction message

1 Ten-pole code switch for setting node ID and baud rate.

1 Six-pole code switch for system configuration

Internal self-checking routine

Every 3 seconds

Periodic testing of output relay contacts

Every 6 hours

Mains supply

230 V +10 / -15 %, 50-60 Hz

115 V +10 / -15 %, 50-60 Hz (option)

24 V +10 / -15 %, 50-60 Hz (option)

Power consumption

10 VA

Protection

Casing: IP 40 to EN 60529

Terminal strip: IP 20 to EN 60529

Technical Data - continued -

NRS 1-40.1 / NRS 1-40.2 - continued -

Admissible ambient temperature

0 – 55 °C

Casing

Casing material: Base: black polycarbonate; front panel: grey polycarbonate,

Cross section of connector: 1 x 4.0 mm² solid or

1 x 2.5 mm² stranded wire with sleeve to DIN 46228 or

2 x 1.4 mm² stranded wire with sleeve to DIN 46228

Terminal strips separately detachable

Fixing of casing: Mounting clip on supporting rail TH 35, EN 60715.

Weight

Approx. 0.8 kg

Name plate / Marking









Safety note		Betriebsanleitung beachten See installation instructions Voir instructions de montage	Steuergerät control device appareil de commande	NRS 1-40.1		Equipment designation
			Node ID: _____			Node ID
Characteristics CAN bus	IN / OUT: CAN-Bus 18-36 V DC		Tamb = 55 °C (131 °F)		230V~ -15/+10% 10VA IP 40 (IP20) 	Mains supply / protection
	Wiring diagram					Alarm ← 3sec.    250 V T 2.5 A Sicherheitsstromkreis protection circuit circuit de sécurité
Type approval no.		Funktionale Sicherheit Functional safety Sécurité fonctionnelle IEC 61508 SIL 2		TÜV . SWB/SHWS STW(STB) . xx-413 DIN STW(STB) xxxxxx		
Fuse	GESTRA AG Münchener Str. 77 D-28215 Bremen				0525	
Manufacturer						CE marking

Fig. 1

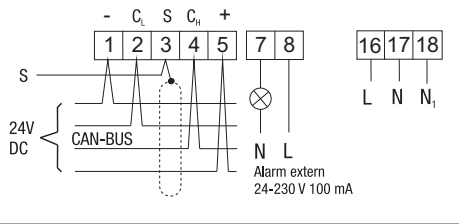
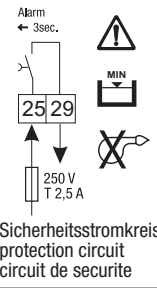
Spare part specification

Dimensions NRS 1-40.1 / NRS 1-40.2

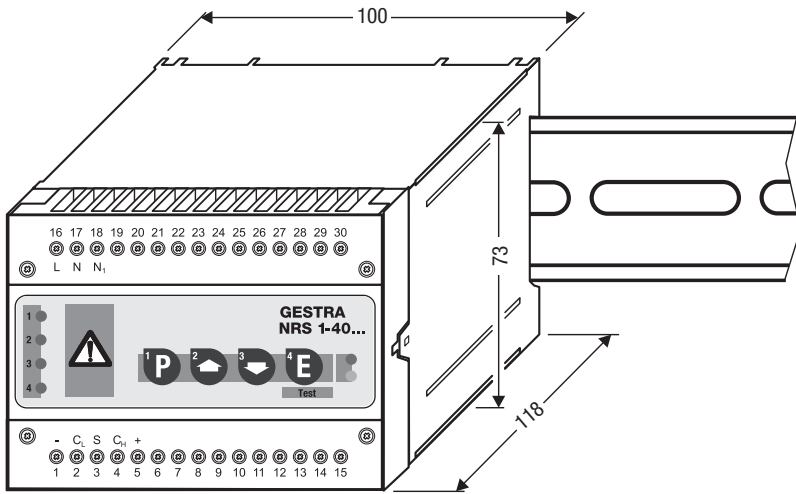

Fig. 2

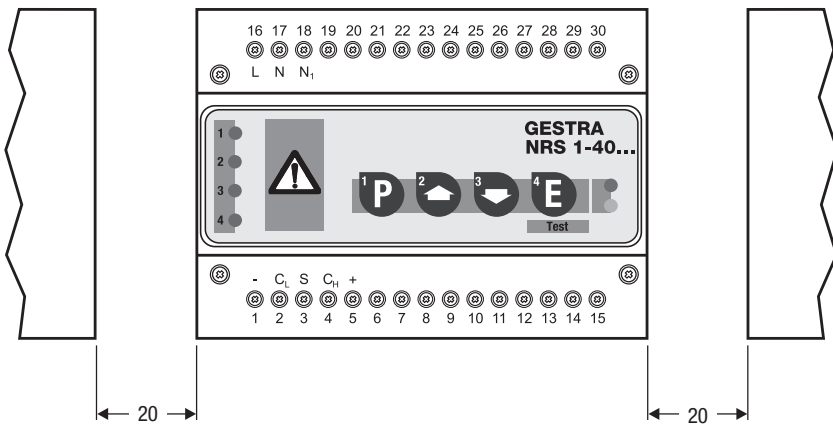

Fig. 3

Installation

Control unit NRS 1-40.1 / NRS 1-40.2



Note

When changing the default factory settings (see page 20) the following steps:

- change baud rate,
- change configuration (see section “Commissioning”) and
- change node ID (see section “Annex”)

must be carried out **before mounting the equipment**. Make sure that the terminal strips are unplugged before performing the work in a single operation.

Change settings

1. Unplug the upper **A** and lower terminal strips **B**. (see **Fig. 4**)
2. The terminal strip can be unplugged after undoing the right and the left fixing screws.
3. Set code switch **D** and **E** as required, **Fig. 4**.
4. Re-insert terminal strips and fasten the fixing screws.

Mount control unit

The control unit NRS 1-40.1 / NRS 1-40.2 is clipped onto a support rail **G** type TH 35, EN 60715 in the control cabinet. (see **Fig. 4**)

Tools

- Screwdriver (5.5/100)

Functional Elements

NRS 1-40.1 / NRS-40.2

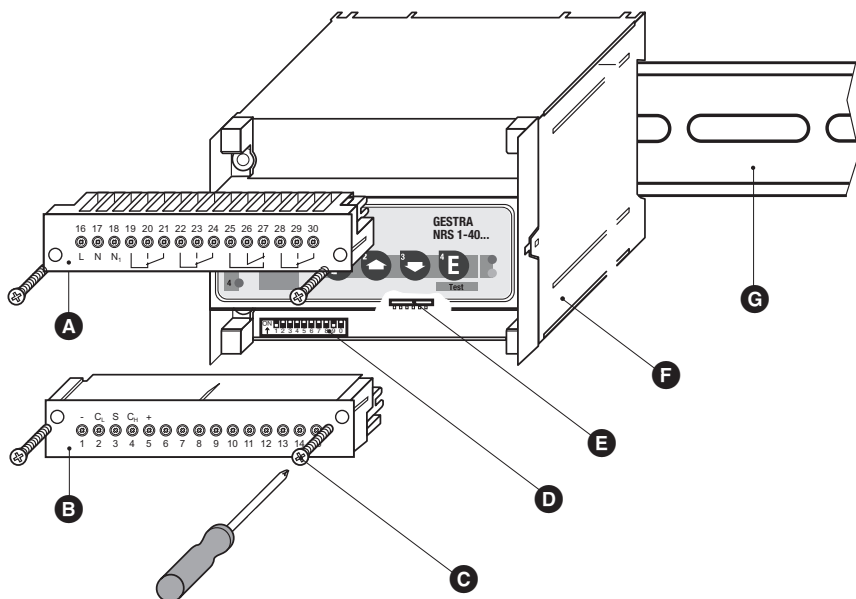

Fig. 4

The code switches are accessible after removing the lower terminal strip. The terminal strips can be unplugged after undoing the right and the left fixing screws.

Key

- A** Upper terminal strip
- B** Lower terminal strip
- C** Fixing screws (cross recess head screws M4)
- D** Code switch for setting node ID and baud rate.
- E** Code switch for system configuration
- F** Casing
- G** Supporting rail type TH 35, EN 60715

Electrical Connection

Bus cable, cable length and size

Note that screened multi-core twisted-pair control cable is required as Bus line, e. g. UNITRONIC® BUS CAN 2 x 2 x ...mm² or RE-2YCYV-fl 2 x 2 x ...mm².

Control cable assemblies (with connector and coupler) of various lengths are available as accessories.

The equipment is fitted with a sensor-connector union (5 poles, A-coded). For connecting the bus devices control cable assemblies (with plug and jack) of various lengths are available as add-on equipment.

Note that the recommended control cables are not UV-resistant and, if installed outdoors, must be protected by a UV-resistant plastic jacket or a cable duct.

The cable length dictates the baud rate (data transfer rate) between the bus nodes, and the total power consumption of the sensor dictates the conductor size.

If the cable length between the steam boiler and the control cabinet exceeds 15 m, we recommend that you fit a branching box that is resistant to electromagnetic interference (stock code no. 1501214) and to use a control cable with a larger conductor size for the distance to the control cabinet.

S 8	S 9	S 10	Baud rate	Cable length	Number of pairs and conductor size [mm ²]
OFF	ON	OFF	250 kBit/s	125 m	2 x 2 x 0.34
Factory setting					
ON	ON	OFF	125 kBit/s	250 m	2 x 2 x 0.5
OFF	OFF	ON	100 kBit/s	335 m	2 x 2 x 0.75
ON	OFF	ON	50 kBit/s	500 m	available on demand (depends on bus configuration)
OFF	ON	ON	20 kBit/s	1000 m	
ON	ON	ON	10 kBit/s	1000 m	

The baud rate is set via code switch **Ⓓ** Fig. 4 (S 8 to S 10). Default factory setting of control unit NRS 1-40.1 / NRS 1-40.2: baud rate 250 kBit/s (cable length up to 125 m). For longer cable lengths reduce baud rate accordingly.

Make sure that all bus nodes feature the same settings.

Change baud rate

To change the baud rate undo the left and right fixing screws, and detach the lower terminal strip. Set the baud rate via code switches **Ⓓ** S 8 to S 10 as specified in the table in section “Bus cable, cable length and size” by using a thin blade screwdriver, Fig. 4. Re-insert terminal strip **Ⓔ** and fasten the fixing screws **Ⓒ**.

Wire terminal strip

Wire terminal strips in accordance with the wiring diagram.

Connect screens only to terminal 3.



Note

The max. baud rates and cable lengths indicated above are based on empirical values obtained by GESTRA. In certain cases it may be necessary to reduce the baud rate in order to ensure trouble-free operation.

Electrical Connection – continued –

CAN Bus voltage supply

To ensure troublefree operation the CAN bus system must be supplied with sufficient voltage. Please use the following table to check the voltage supply of your bus system.

Control units with voltage supply	Qty.		Power rating per equipment		Sum 1
		x	6 W	=	W

Measuring transducers, transmitters, control units, operating & display unit URB 1	Qty.		Power rating per equipment		Sum
		x	3 W	=	W
Operating & display unit URB 2		x	5 W	=	W
			Sum 2	=	W

If sum 2 exceeds sum 1, the CAN bus voltage must be supplied by a separate, stabilised safety power supply unit (e.g. SITOP Smart 24 V 2.5 A) with 24 V DC.

The power supply unit must meet the requirements of the DIN VDE 0106 (safety separation) and be provided with an overcurrent protective device in accordance with EN 61010-1 / VDE 0411.

Note that the CAN bus supply must then not be connected to the control units (terminals 1 and 5).

Wiring diagram for control unit NRS 1-40.1

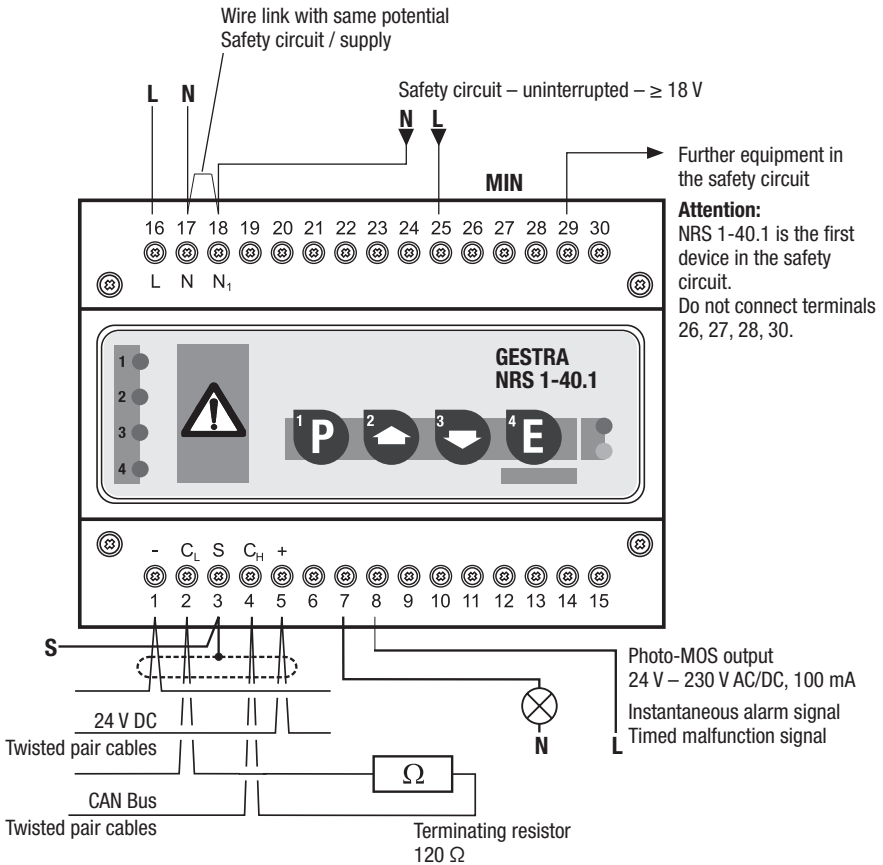

Fig. 5

Wiring diagram for control unit NRS 1-40.2

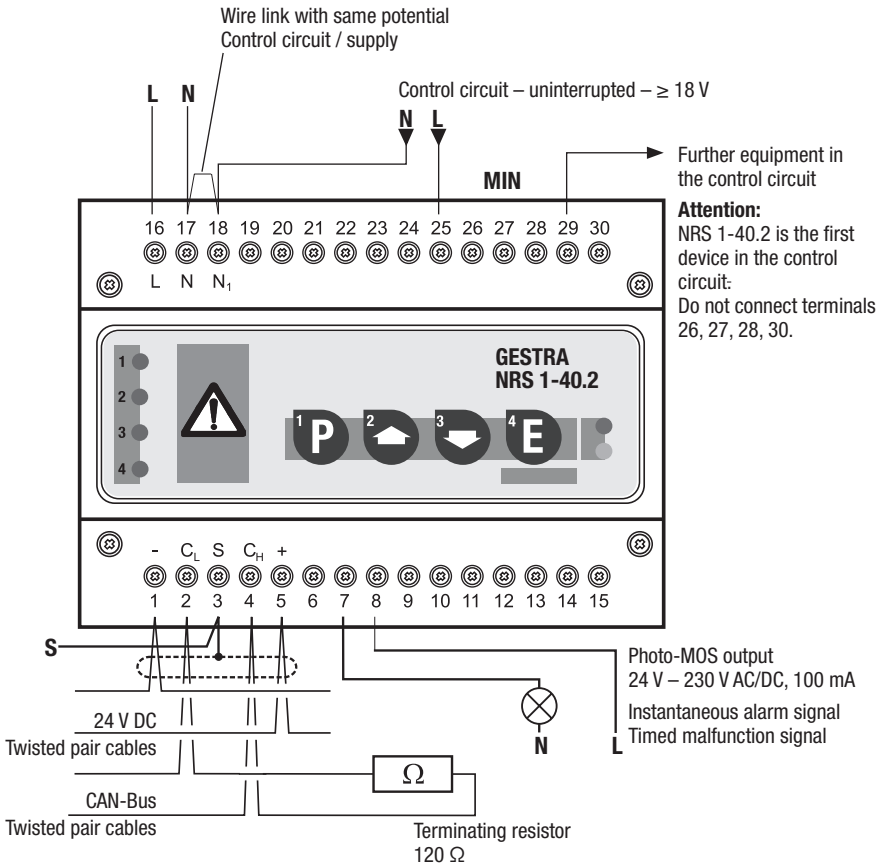

Fig. 6

Wiring diagram for CAN bus system – example –

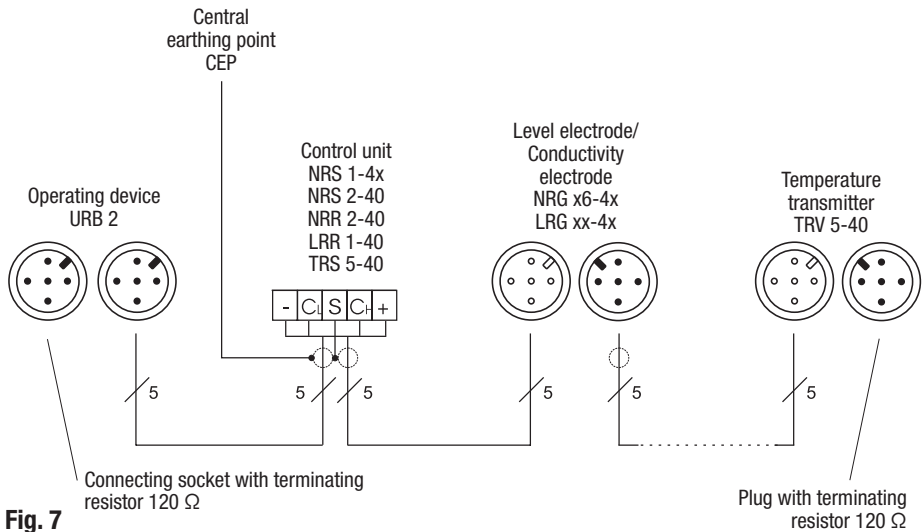

Fig. 7



Attention

- Wire equipment in series. Star-type wiring is not permitted!
- Link screens of bus cables such that electrical continuity is ensured and connect them **once** to the central earthing point (CEP).
- Because of the self-checking routine of the output contacts the control unit NRS 1-40.1 / NRS 1-40.2 must always be the **first** equipment in the safety circuit, which means that terminal 25 must be permanently connected to L of the safety circuit.
- Terminal N₁ (18) must be permanently connected to the zero potential (N) of the safety circuit. Non-compliance will cause malfunctions, in particular if the control unit and the safety circuit are supplied with different voltage potentials (e. g. control unit 230 V / safety circuit 24 V). Provided that the electric potentials are equal, a wire link can be attached to terminals 17 and 18.
- To protect the switching contacts provide the circuit with a T 2.5 A or 1.0 A fuse (TRD 604, 72 hrs. operation).
- If two or more system components are connected in a CAN bus system, provide the first and the last device with a terminating resistor of 120 Ω (terminal C_L/C_H).
- Only one control unit NRS 1-40.1 / NRS 1-40.2 may be used per CAN bus network.
- The CAN bus system must not be interrupted during operation.
In the event of an interruption a malfunction alarm is raised.



Note

- **The control units NRS 1-40.1 / NRS 1-40.2 can switch off different electric circuits, e. g. the safety circuit for the heating system and the control circuit for the feed pumps or circulation pumps.**
- Connect screen only to the respective terminals and to the central earthing point (CEP).
- The rated voltage is indicated on the name plate.
- When switching off inductive loads, voltage spikes are produced that may impair the operation of control and measuring systems. Connected contactors must therefore be provided with suppressors such as RC combinations.
- In the event of an alarm the signal output (terminal 7 and 8) is instantaneously closed.
- In the event of a malfunction the signal output (terminals 7 and 8) is opened and closed in a clock-pulse controlled way in order to ensure an optical differentiation between an alarm and a malfunction signal. If required you can wire terminals 7 and 8 with an external signal lamp.

Tools

- Screwdriver for slotted screws, size 2.5, completely insulated according to VDE 0680-1
- Screwdriver for cross head screws, size 2

Basic Settings

Factory settings

Control unit NRS 1-40.1

The control unit features the following factory set default values:

- Node ID: 1
- Baud rate: 250 kBit/s (125 m cable length)
- De-energizing delay: 3 sec.
- Configuration: Operation with two level electrodes NRG 1x-40, one level electrode NRG 1x-41.1 and one temperature transmitter TRV 5-40.

Control unit NRS 1-40.2

The control unit features the following factory set default values:

- Node ID: 6
- Baud rate: 250 kBit/s (125 m cable length)
- De-energizing delay: 3 sec.
- Configuration: Operation with two temperature transmitters TRV 5-40.

Commissioning



Danger

The terminal strips of the control units NRS 1-40.1 / NRS 1-40.2 are live during operation. This presents the risk of severe cases of electric shock!

Always **cut off power supply** to the equipment before mounting, removing or connecting the terminal strips **A**, **B**!

Change configuration

The control unit NRS 1-40.1 features four limiting functions for monitoring water level and temperature. The level electrodes NRG 1x-40, NRG 1x-41.1 and the temperature transmitter TRV 5-40 can be connected to the control unit.

The control unit NRS 1-40.2 also features four limiting functions. The level electrode NRG 1x-41 and the temperature transmitters TRV 5-40 can be connected to the control unit.

For the operation in question the required number of limiting functions of the control unit has to be ascertained.

With lower terminal strip unplugged:

Set the baud rate via code switch **B** **Fig. 4** (S 1 to S 6) as specified in the table by using a thin blade screwdriver.

Re-insert terminal strip **B** and fasten the fixing screws **C**.

Since the components are easier to access before the equipment is mounted you should change the configuration before carrying out the installation.

Change configuration – continued –

Control unit NRS 1-40.1



Toggle switch, white

Code switch E						Limiting function			
S1	S2	S3	S4	S5	S6	1	2	3	4
OFF	OFF	ON	ON	ON	ON	Water level LW 1			
ON	ON	ON	ON	ON	ON	Water level LW 1	Water level LW 2		
Factory setting									
ON	ON	OFF	OFF	ON	ON	Water level LW 1	Water level LW 2	Temperature MAX 1	
ON	ON	OFF	OFF	OFF	OFF	Water level LW 1	Water level LW 2	High level HW	Temperature MAX
ON	ON	OFF	OFF	ON	ON	Water level LW 1	Temperature MAX 1	Temperature MAX 2	
ON	ON	OFF	OFF	OFF	OFF	Water level LW 1	Water level LW 2	Temperature MAX 1	Temperature MAX 2
OFF	OFF	ON	ON	ON	ON	Temperature MAX 1			
ON	ON	ON	ON	ON	ON	Temperature MAX 1	Temperature MAX 2		

Control unit NRS 1-40.2



Toggle switch, white

Code switch E						Limiting function			
S1	S2	S3	S4	S5	S6	1	2	3	4
OFF	OFF	ON	ON	ON	ON	High level HW			
ON	ON	OFF	OFF	ON	ON	High level HW	Temperature MAX	Temperature MAX	
OFF	OFF	ON	ON	ON	ON	Temperature MAX 1			
Factory setting									
ON	ON	ON	ON	ON	ON	Temperature MAX 1	Temperature MAX 2		



Note

When determining the limiting functions 1 – 4 please take also the installation instructions of the level electrodes NRG 1x-40, NRG 1x-41.1 and the temperature transmitter TRV 5-40 into account.

Start, Operation, Alarm and Test

NRS 1-40.1 / NRS 1-40.2

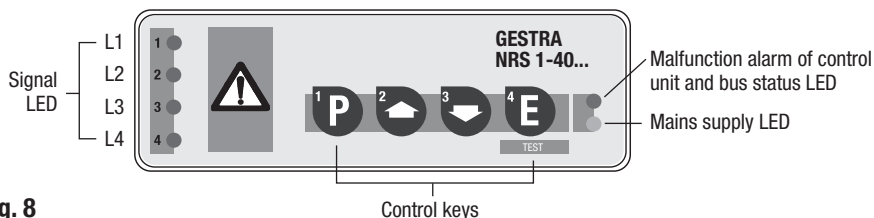

Fig. 8

Assignment of signal LED / key / equipment

- LED 1 / Key 1: Limiter 1
- LED 2 / Key 2: Limiter 2
- LED 3 / Key 3: Limiter 3
- LED 4 / Key 4: Limiter 4

Start		
Apply mains voltage.	LED "Power" is illuminated	Mains voltage applied
	LED 1-4 are flashing	System is being started and tested. Output contacts are open. Signalling output is closing (lamp test).

Operation		
Limiters 1-4 indicate no alarm	LED 1-4 are not illuminated	Output contacts are closed, signalling output is open.

Alarm		
Limiters 1-4, one or more limiters indicate an alarm	One or more of the LEDs 1, 2, 3, 4 are flashing rapidly	De-energizing initiated, signalling output is closed instantaneously.
	One or more of the LEDs 1, 2, 3, 4 are illuminated	De-energizing period has elapsed, output contacts are open, signalling output closed.

Test - Limiters 1-4		
During operation: Press key 1, 2, 3 or 4 and hold it down until the end of the test, limiters must react as if there was an alarm.	LED 1, 2, 3 or 4 is flashing rapidly	Alarm simulated in limiter 1 - 4. De-energizing initiated, signalling output is closed instantaneously.
	LED 1, 2, 3 or 4 is illuminated	De-energizing period has elapsed, output contacts are open, signalling output closed. Test finished.



Note

- In the event of an alarm the control unit NRS 1-40.1 / NRS 1-40.2 does not lock automatically. If a lock function is required by the installation it must be provided in the follow-up circuitry (safety circuit). This circuit must meet the requirements of DIN VDE 0116 (EN 50156).

System Malfunctions

Causes

Malfunctions occur if CAN bus components have been mounted or configured incorrectly or if electronic component parts are defective, or in the event of excessive heat in the equipment or electrical interference in the supply system.

Further malfunctions are:

- Faulty communication within the CAN-Bus system
- Overloading of the 24 V power supply unit in the controller



Note

Before carrying out the systematic fault finding procedure please check:

Wiring:

Is the wiring in accordance with the wiring diagram?

Is the polarity of the bus line always correct?

Is the bus line of each of the end nodes provided with a 120 Ω resistor?

Configuration of level electrode NRG 1x-40 (low water level LW):

Are the wire links (device 1 or 2) set correctly?

Does the position of the wire link tally with the node ID?

Configuration of the temperature transmitter TRV 5-40

Is the transmitter correctly adjusted as device 1, 2, 3 or 4?

Node ID:

Are the node IDs set correctly?

Note that a node ID must only be used for one item of equipment!

Baud rate:

Is the length of the cable in accordance with the adjusted baud rate?

Is the baud rate setting the same for all devices?



Danger

The terminal strips of the control unit NRS 1-40.1 / NRS 1-40.2 are live during operation. This presents the risk of severe cases of electric shock!

Always **cut off power supply** to the equipment before mounting, removing or connecting the terminal strips! When the CAN bus is interrupted during operation an alarm will be raised.

Systematic fault finding procedure for system malfunctions

The sources of malfunctions occurring in CAN bus systems operating with several bus-based stations must be analysed systematically since faulty components or incorrect settings can give rise to negative interactions with intact bus devices in the CAN bus system. These unwanted interactions can cause error messages in fully functional bus devices, which will make fault detection even more difficult.

We recommend the following systematic fault finding procedure:

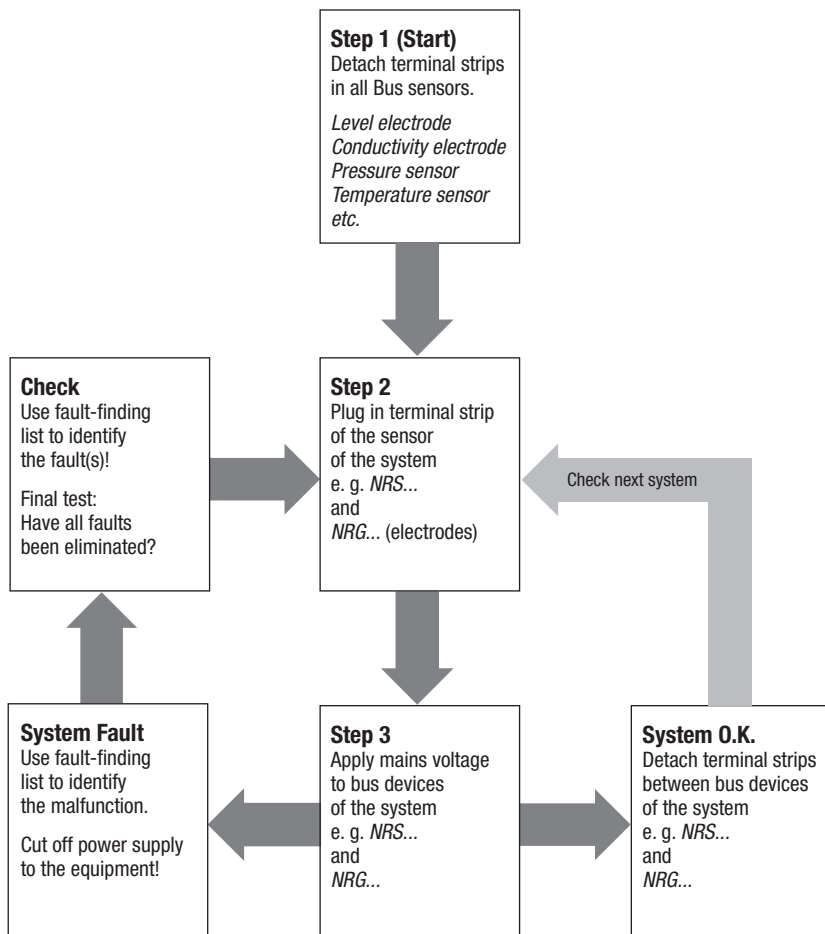

Fig. 9

System Malfunctions – continued –

Systematic fault finding procedure for system malfunctions – continued –

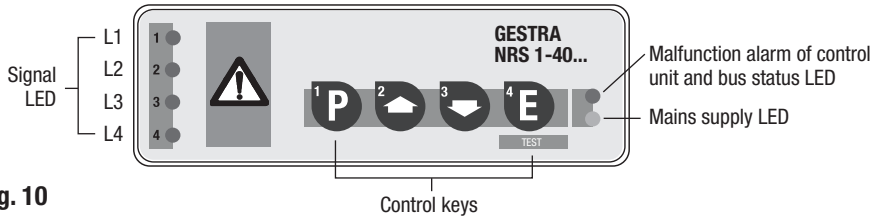

Fig. 10

Assignment of signal LED / key / equipment:

- LED 1 / Key 1: Limiter 1
- LED 2 / Key 2: Limiter 2
- LED 3 / Key 3: Limiter 3
- LED 4 / Key 4: Limiter 4

Indication of system malfunctions in limiters 1 – 4		
Limiters 1–4, one or more limiters have a malfunction	LED 1, 2, 3, 4, one or more LEDs are flashing slowly	Output contacts open instantaneously. Signalling output is operating in the switching mode.

Analysis of system malfunctions in limiters 1 – 4			
Limiters 1–4, one or more limiters have a malfunction. LED 1, 2, 3, 4, one or more LEDs are flashing slowly	Press and hold down corresponding key (key 1, 2, 3 or 4)	LED 1 is flashing slowly	Faulty communication between limiter and controller, HF interference
		LED 2 and 3 are flashing slowly	Excessively high temperature in the terminal box of the electrode or the temperature transmitter
		LED 3 is flashing slowly	Sensor defective.

Analysis of system malfunctions in the controller		
Malfunction in control unit	LED bus status is flashing slowly	Faulty communication within the CAN bus system. HF interference
	LED bus status is illuminated	Control unit defective. Output contacts open instantaneously. Switched mode signalling output, frequency 2.5 Hz.
	LED Power is flashing slowly	Bus supply voltage below 18 V.

System Malfunctions – continued –

Fault finding list for troubleshooting system malfunctions: Limiters 1 – 4

Depending on the indication of the malfunction press and hold down key 1 or 2 or 3 or 4.

LED 1 is flashing slowly

Fault: The **limiter** (level electrode / temperature transmitter) and **the control unit** cannot communicate.

Remedy: Check 24 V bus supply, wiring, configuration of the low level electrodes (wire links), node ID, baud rate setting and terminating resistor. If modifications have to be made, switch off mains voltage and switch it on again after about 5 seconds.

Fault: The **limiter** and the **controller** cannot communicate. The fault occurs at long intervals.

Remedy: There is a source of interference in the surrounding area. To suppress interferences provide contactors and actuators with RC combinations in accordance with the specifications of the manufacturer. Take action against high frequency interference.

LEDs 2 and 3 are flashing slowly

Fault: The temperature in the terminal box of the level electrode or the temperature transmitter exceeds the max. limit.

Remedy: Check installation of electrode and insulate electrode flange against thermal radiation. Check place of installation of the temperature transmitter.

LED 3 is flashing slowly

Fault: One or more of the self-checking routines detected a malfunction, which means that the electronic insert of the level electrode or the temperature transmitter is defective.

Remedy: Replace electronic insert.

Fault: The temperature sensor is defective (parting of a cable, short circuit).

Remedy: Check temperature sensor and supply cables (see Installation Instructions TRV 5-40), replace measuring element of the temperature sensor.

System Malfunctions – continued –

Fault finding list for troubleshooting system malfunctions: Control unit

LED bus status is flashing slowly

Fault: Faulty communication in the CAN bus system.

Remedy: Check 24 V bus supply, wiring, configuration of the limiter, node ID and baud rate settings as well as terminating resistors. If modifications have to be made, switch off mains voltage and switch it on again after about 5 seconds.

Fault: No or faulty communication with limiters. The fault occurs at long intervals.

Remedy: There is a source of interference in the surrounding area. To suppress interferences provide contactors and actuators with RC combinations in accordance with the specifications of the manufacturer. Take action against high frequency interference.

LED bus status is illuminated

Fault: The control unit must be defective because one or more of the self-checking routines detected a malfunction, e. g. faulty output relay in the control unit, no or clock-pulse controlled voltage applied across terminal 25.

Remedy: Switch off mains voltage and switch it on again after about 5 seconds (the equipment restarts). The control unit must be replaced if after a maximum of 1 minute a malfunction is indicated again.

LED Power is flashing slowly

Fault: Bus supply voltage below 18 V DC. The power supply unit of the controller is overloaded.

Remedy: Mount and connect a safety power supply unit (e. g. Siemens SITOP Power 05).

Fault: Bus supply voltage below 18 V DC. Faulty wiring (short circuit).

Remedy: Check wiring. Switch off mains voltage and switch it on again after about 1 minute (the equipment restarts).

Action against high frequency interference

All connected inductive loads such as contactors and actuators must be provided with RC combinations in accordance with the specifications of the manufacturer.

Should sporadic failures occur in installations susceptible to faults (e. g. malfunctions due to out-of-phase switching operations) we recommend the following actions in order to suppress interferences:

HF interference suppression of voltage supply by means of ferrite rings and

HF interference suppression of CAN bus line by means of hinged-shell ferrite rings.

System Malfunctions – continued –

Replace control unit

1. **Cut off power supply** to the equipment!
2. Remove terminal strips **A**, **B**. For this purpose turn the right and left fixing screws **C** in direction of the arrow until the terminal strip can be removed.
3. Undo the fixing slide in order to snap out the controller and take it off the supporting rail **D**.

When ordering spare parts please state the serial number indicated on the name plate.

Check Installation and Performance

Check switchpoints

In order to check the switchpoints “Level below low water level (LW)” or “Level above high water level (HW)” the water level must be lowered or – as the case may be – the boiler must be filled.

The switchpoint “MAX temperature” can also only be checked by increasing the temperature accordingly. All devices must respond as if there were an alarm.

Check switchpoints after commissioning or replacing the level electrode, temperature sensor or temperature transmitter.

Malfunctions

Fault finding list for level electrode NRG 1.-40 / control unit NRS 1-40.1

Water level below switchpoint “Low water (LW)” – no low level alarm

Fault: LED “Power” and LEDs 1 - 4 are not illuminated.

Remedy: Apply mains voltage, wire equipment in accordance with wiring diagram.

Fault: The electrode rod(s) is/are too long.

Remedy: Cut electrode rod(s) to the length dictated by the switchpoint LW.

Fault: If the electrode is installed inside the boiler: The vent hole in the protection tube does not exist or is obstructed.

Remedy: Check installation of level electrode. Make sure that the level in the protection tube corresponds to the actual water level.

Water level not yet below switchpoint “Low water (LW)” – but a low level alarm is raised

Fault: The electrode rod(s) is/are too short.

Remedy: Replace electrode rod(s) and cut electrode rod(s) to the length dictated by the switchpoint LW.

Fault: The earth connection to the vessel is interrupted.

Remedy: Clean seating surfaces and screw in the electrode together with the supplied joint ring Ø 27 x 32 DIN 7603. Do not insulate the electrode with hemp or PTFE tape!

Fault: The insulation of the level electrode is faulty.

Remedy: Replace level electrode.

Malfunctions – continued –

Fault finding list for level electrode NRG 1.-41.1 / control unit NRS 1-40.1

Fault finding list for level electrode NRG 1.-41 / control unit NRS 1-40.2

Switchpoint “High water (HW)” exceeded – no high level alarm

Fault: LED “Power” and LEDs 1 – 4 are not illuminated.

Remedy: Apply mains voltage, wire equipment in accordance with wiring diagram.

Fault: The electrode rod is too short.

Remedy: Replace electrode rod and cut electrode rod to the length dictated by the switchpoint HW.

Fault: If the electrode is installed inside the boiler: The vent hole in the protection tube does not exist or is obstructed.

Remedy: Check installation of level electrode. Make sure that the level in the protection tube corresponds to the actual water level.

Fault: The earth connection to the vessel is interrupted.

Remedy: Clean seating surfaces and screw in the electrode together with the supplied joint ring \varnothing 27x 32 DIN 7603. Do not insulate the electrode with hemp or PTFE tape!

Switchpoint “High water (HW)” not yet exceeded – but a high level alarm is raised

Fault: The electrode rod is too long.

Remedy: Cut electrode rod to the length dictated by the switchpoint HW.

Fault: The insulation of the level electrode is faulty.

Remedy: Replace level electrode.

Fault finding list for temperature transmitter TRV 5-40 / control unit NRS 1-40.1 / NRS 1-40.2

Switchpoint “MAX temperature” not yet exceeded – but a MAX temperature alarm is raised

Fault: The temperature sensor is defective.

Remedy: Check whether the temperature sensor (Pt 100) gives correct readings (basic values of measuring resistors to DIN 43760 for Pt 100). In case of incorrect readings replace the measuring element of the temperature sensor.

If faults occur that are not listed above or cannot be corrected, please contact our service centre or authorized agency in your country.

Emergency Operation

Emergency operation of water level limiting system LW

Provided that the control unit works with two level electrodes NRG 1x-40 (water level limiting system), if one level electrode fails to operate the installation can continue to operate in emergency mode with **one** level electrode under constant supervision according to TRD 401 and EN 12952 and EN 12953.

The following settings are required:

1. Set the wire link to the left in order to configure the working level electrode as device 1 and set the node ID to "2" (see "**Emergency Operation**" in the installation manual of NRG 1x-40).
2. **Control unit: Cut off power supply** and unplug the lower terminal strip **B**.
3. The terminal strip can be unplugged after undoing the right and the left fixing screws **C**.
4. Set switch S1 of the code switch **D Fig. 4** to ON and S2 to S7 to **OFF**. The control unit NRS 1-40.1 has now the node ID 1.
5. Set switches S1 and S2 of the code switch **E Fig. 4** to **OFF**.
6. Re-insert terminal strip **B** and fasten the fixing screws **C**.



Attention

- Enter beginning of emergency operation in the boiler log.
- An installation operating in emergency mode has to be constantly supervised!
- Immediately replace faulty level electrode.
- Enter end of emergency operation in the boiler log.

Annex

CAN bus

All devices (level, conductivity, temperature) are interconnected via CAN bus.

The CANopen protocol is used for the data exchange between the equipment groups. All devices have an electronic address – the node ID. The four-core bus cable serves as power supply and data highway for high-speed data exchange.

Setting the node ID

Due to the interdependence of the equipment, set the node IDs of the individual devices as follows:

Control unit NRS 1-40.1

Control unit NRS 1-40.1	Sensor 1 e. g. level electrode NRG 1.-40 as device 1	Sensor 2 e. g. level electrode NRG 1.-40 as device 2	Sensor 3 e. g. level electrode NRG 1.-41.1	Sensor 4 e. g. Temperature transmitter TRV 5-40
X	X + 1	X + 2	X + 3	X + 4
1	2	3	4	5

Reserved area

Control unit NRS 1-40.2

Control unit NRS 1-40.2	Sensor 1 e. g. level electrode NRG 1.-41	Sensor 2 e. g. Temperature transmitter TRV 5-40	Sensor 3 e. g. Temperature transmitter TRV 5-40	
X	X + 1	X + 2	X + 3	
6	7	8	9	

Reserved area

Setting the Node ID – continued –

To set the node ID remove the right and left fixing screws and detach the lower terminal strip.

Set the node ID via code switches **D** Fig. 4 (S1 to S7) as specified in the above table “Node ID” by using a thin blade screwdriver.

Re-insert terminal strip **B** and fasten the fixing screws **C**. Enter the adjusted node ID on the name plate.



Toggle switch, white



Toggle switch, white

		Node ID	1
S1	ON	1	
S2	OFF	2	
S3	OFF	4	
S4	OFF	8	
S5	OFF	16	
S6	OFF	32	
S7	OFF	64	

Factory setting NRS 1-40.1

		Node ID	6
S1	OFF	1	
S2	ON	2	
S3	ON	4	
S4	OFF	8	
S5	OFF	16	
S6	OFF	32	
S7	OFF	64	

Factory setting NRS 1-40.2

Fig. 11



Note

- When setting the node ID please take also the instructions given in the installation manuals of the level electrodes NRG 1x-40, NRG 1x-41, NRG 1x-41.1 and the temperature transmitter TRV 5-40 into account.



Danger

The terminal strips of the control unit NRS 1-40.1 / NRS 1-40.2 are live during operation. This presents the risk of severe cases of electric shock!
Always **cut off power supply** to the equipment before mounting, removing or connecting the terminal strips!



Attention

A node ID must only be used for one piece of equipment in the CAN bus system. The node ID 0 is not permissible.

Decommissioning

First unplug the terminal strips **A**, **B**. For this purpose turn the right and left fixing screws **C** in direction of the arrow until the terminal strip can be removed.

Undo the fixing slide in order to snap out the controller and take it off the supporting rail.

Disposal

Dismantle the control unit and separate the waste materials according to the material specification. Electronic component parts such as the circuit board must be disposed of separately! For the disposal of the control unit observe the pertinent legal regulations concerning waste disposal.

For your notes



Agencies all over the world: www.gestra.de

GESTRA AG

Münchener Straße 77

28215 Bremen

Germany

Telefon +49 421 3503-0

Telefax +49 421 3503-393

E-mail info@de.gestra.com

Web www.gestra.de